



## FALL PROTECTION TRAINING OSHA - SUSAN HARWOOD TRAINING GRANT

## WELCOME

- Please sign the attendance sheet
- Take one handout
- Fill the registration form
- Answer the pre-test



Susan Harwood Training Grant Program

2

## LOCATION

- Emergency Exits
- Emergency Stairs
- Location of restrooms
- Location of water fountains



Susan Harwood Training Grant Program

3

## DISCLAIMER

This material was produced under grant number SH-31201-SH7 from the Occupational Safety and Health Administration, U.S. Department of Labor. It does not necessarily reflect the views or policies of the U. S. Department of Labor, nor does mention of trade names, commercial products, or organizations imply endorsement by the U. S. Government.

Revisions were made to this material under grant number SH-37148-SH1 from the Occupational Safety and Health Administration, U.S. Department of Labor.



Susan Harwood Training Grant Program

4

## AGENDA

- Welcome
- Introduction to OSHA
- Worker's rights
- Introduction to Fall Protection
  - Recognition of Fall Hazards
  - Basic Fall Prevention Principles
  - Basic Fall Protection Principles
  - Brief Review of Applicable Standards



➤ Break



Susan Harwood Training Grant Program

5

## AGENDA

- Controlling the Hazard
  - Hierarchy of Controls
  - Restrain
  - Components
  - Fall Clearance
  - Inspections
- Rescue



➤ Certificates



Susan Harwood Training Grant Program

6

# INTRODUCTION TO OSHA

Overview of anti-retaliation provisions, employee rights, employer responsibilities, whistleblower laws, and OSHA's complaint investigation procedures

## WHY IS OSHA IMPORTANT TO YOU?

- OSHA began because, until 1970, there were no national laws for safety and health hazards.
- On average, 13 workers die every day from job injuries
- Worker deaths in America are down—on average, from about 38 worker deaths a day in 1970 to 13 a day in 2020.
- **WORKER FATALITIES**
- 4,764 workers were killed on the job in 2020
- Falls accounted for 805 out of 4,764 total deaths (17%)

## DISCUSSION QUESTIONS

- When, during your work experience, did you first hear about OSHA?
- What did you think about OSHA then?
- What do you think OSHA's job is?

## HISTORY OF OSHA

- OSHA stands for the Occupational Safety and Health Administration, an agency of the U.S. Department of Labor
- OSHA's responsibility is worker safety and health protection
- On December 29, 1970, President Nixon signed the OSH Act
- This Act created OSHA, the agency, which formally came into being on April 28, 1971



## OSHA'S MISSION

**All workers have the right to:**

- A safe workplace.
- Raise a safety or health concern with your employer or OSHA, or report a work-related injury or illness, without being retaliated against.
- Receive information and training on job hazards, including all hazardous substances in your workplace.
- Request an OSHA inspection of your workplace if you believe there are unsafe or unhealthy conditions. OSHA will keep your name confidential. You have the right to have a representative contact OSHA on your behalf.
- Participate (or have your representative participate) in an OSHA inspection and speak in private to the inspector.
- File a complaint with OSHA within 30 days by phone, online or by mail if you have been retaliated against for using your rights.
- See any OSHA citations issued to your employer.
- Request copies of your medical records, tests that measure hazards in the workplace, and the workplace injury and illness log.

This poster is available free from OSHA.

**Contact OSHA. We can help.**

1-800-321-OSHA (6742) • TTY 1-877-889-5627 • www.osha.gov

## STRATEGIES TO REDUCE INJURIES AND DEATHS

- Strong, fair, and effective enforcement.
- Outreach, education, and compliance assistance.
- Partnerships and other cooperative programs.











**Outreach Training Program**

Construction | General Industry | Maritime | Disaster Site

**PARTNERSHIP**  
An OSHA Cooperative Program

### HCS Pictograms and Hazards

Labels for hazardous substances in your workplace

<b>Health Hazard</b>  <ul style="list-style-type: none"> <li>• Carcinogen</li> <li>• Mutagenicity</li> <li>• Reproductive Toxicity</li> <li>• Respiratory Sensitizer</li> <li>• Target Organ Toxicity</li> <li>• Aspiration Toxicity</li> </ul>	<b>Flame</b>  <ul style="list-style-type: none"> <li>• Flammables</li> <li>• Pyrophorics</li> <li>• Self-Heating</li> <li>• Emits Flammable Gas</li> <li>• Self-Reactives</li> <li>• Organic Peroxides</li> </ul>	<b>Exclamation Mark</b>  <ul style="list-style-type: none"> <li>• Irritant (skin and eye)</li> <li>• Skin Sensitizer</li> <li>• Acute Toxicity (harmful)</li> <li>• Narcotic Effects</li> <li>• Respiratory Tract Irritant</li> <li>• Hazardous to Ozone Layer (Non-Mandatory)</li> </ul>
<b>Gas Cylinder</b>  <ul style="list-style-type: none"> <li>• Gases Under Pressure</li> </ul>	<b>Corrosion</b>  <ul style="list-style-type: none"> <li>• Skin Corrosion/ Burns</li> <li>• Eye Damage</li> <li>• Corrosive to Metals</li> </ul>	<b>Exploding Bomb</b>  <ul style="list-style-type: none"> <li>• Explosives</li> <li>• Self-Reactives</li> <li>• Organic Peroxides</li> </ul>
<b>Flame Over Circle</b>  <ul style="list-style-type: none"> <li>• Oxidizers</li> </ul>	<b>Environment (Non-Mandatory)</b>  <ul style="list-style-type: none"> <li>• Aquatic Toxicity</li> </ul>	<b>Skull and Crossbones</b>  <ul style="list-style-type: none"> <li>• Acute Toxicity (fatal or toxic)</li> </ul>

**Labels for a hazardous chemical must contain:**

- Name, Address and Telephone Number
- Product Identifier
- Signal Word
- Hazard Statement(s)
- Precautionary Statement(s)
- Pictogram(s)

## OSHA INSPECTIONS

- The OSH Act authorizes OSHA compliance safety and health officers (CSHOs) to conduct workplace inspections at reasonable times.
- OSHA conducts inspections without advance notice, except in rare circumstances (e.g. Imminent Danger)
- In fact, anyone who tells an employer about an OSHA inspection in advance can receive fines and a jail term.

## INSPECTIONS PROCESS

- A typical OSHA on-site inspection includes four stages:
  1. Presentation of inspector credentials.
  2. An opening conference.
  3. An inspection walk-around.
  4. A closing conference.

## OSHA'S INSPECTION PRIORITIES

Priority	Category of Inspection
1st	<b>Imminent Danger:</b> <i>Reasonable certainty an immediate danger exists</i>
2nd	<b>Fatality/Catastrophe:</b> <i>Reported to OSHA; inspected ASAP</i>
3rd	<b>Complaints/Referrals:</b> <i>Worker or worker representative can file a complaint about a safety or health hazard</i>
4th	<b>Programmed Inspections:</b> <i>Cover industries and employers with high injury and illness rates, specific hazards, or other exposures.</i>

## OSHA'S COMPLAINT INVESTIGATIONS

- OSHA evaluates each complaint to determine how it can be handled best--an off-site investigation or an on-site inspection
- Before beginning an inspection, OSHA staff must be able to determine from the complaint that there are reasonable grounds to believe that a violation of an OSHA standard or a safety or health hazard exists.
- If OSHA has information indicating the employer is aware of the hazard and is correcting it, the agency may not conduct an inspection after obtaining the necessary documentation from the employer.

## RIGHTS AS A WHISTLEBLOWER

- Employee may file a complain with OSHA under Section 11(c) if your employer retaliates against you by taking unfavorable personnel action because you engaged in protected activity relating to workplace safety and health.
- OSHA requires that complaints must be filed within 30 days after the alleged retaliation.

## RIGHTS AS A WHISTLEBLOWER

- Your employer may be found to have retaliated against you if your protected activity was a contributing or motivating factor in its decision to take unfavorable personnel action against you. Such actions may include:

- ✧ Firing or laying off
- ✧ Blacklisting
- ✧ Denying overtime or promotion
- ✧ Disciplining
- ✧ Denying benefits
- ✧ Failing to hire or rehire
- ✧ Intimidation
- ✧ Reassignment affecting promotion prospects
- ✧ Reducing pay or hour

## QUESTIONS ABOUT OSHA?

## INTRODUCTION TO FALL PROTECTION

## OBJECTIVES

- Recognize, avoid and prevent fall hazards in construction
  - Identify major fall hazards
  - Describe types of fall hazards
  - Protect him/herself from fall hazards
  - Recognize employer requirements to protect workers from fall hazards

## FALLS IN CONSTRUCTION

- Did you know?  
Falls from elevation account for one third of all deaths in construction.



## FALLS IN CONSTRUCTION

- FALLS ARE THE LEADING CAUSE OF DEATH IN CONSTRUCTION.
- In 2020, there were 805 fatal falls out of 4,764 workplace deaths (BLS data). These deaths are preventable.

## FALLS IN CONSTRUCTION

- It is important that safety and health programs contain provisions to protect workers from falls on the job.
- The following hazards cause the most fall-related injuries:
  - Unprotected Sides, Wall Openings, and Floor Holes
  - Unguarded Protruding Steel Rebar
  - Improper Scaffold Construction
  - Misuse of Portable Ladders

## OSHA REGULATIONS ON FALL PROTECTION

### ✓ General Industry:

Fall protection required when working at 4 feet above lower level

### ✓ Construction Industry:

Fall protection required when working at 6 feet above lower level

- Employer's operations will completely or mostly fall under one of the sectors listed and will follow their regulations.

## OSHA'S FALL PREVENTION CAMPAIGN

**PLAN**  
*ahead to get the job done safely.*

---

**PROVIDE**  
*the right equipment.*

---

**TRAIN**  
*everyone to use the equipment safely.*

## OSHA'S FALL PREVENTION CAMPAIGN

### PLAN ahead to get the job done safely

When working from heights, such as ladders, scaffolds, and roofs, employers must plan projects to ensure that the job is done safely.

### PROVIDE the right equipment

Workers who are six feet or more above lower levels are at risk for serious injury or death if they should fall.

### TRAIN everyone to use the equipment safely

Falls can be prevented when workers understand proper set-up and safe use of equipment.

## ROOF SAFETY

- Employees must be trained to avoid fall hazards on a roof and properly use fall protection equipment-this includes safety measures like:
  - ✓ Make sure your harness fits and is not defective when using PFAS
  - ✓ Always stay connected/tie off
  - ✓ Ensure that all anchor points are safe
  - ✓ Protect all holes, openings and skylights
  - ✓ Don't sit or walk on skylights or other openings

## WARNING LINES – 1926 ROOFING

- 4-sided set of lines in-place to warn workers of edge hazard
  - **NOT** a guardrail
  - Distances from edge:
    - ✓ 6' - General
    - ✓ 10' - "Mechanical Equipment"
  - Permit work inside w/ no PFAS
  - Points of access, materials handling areas, storage areas, and hoisting areas connected by access path formed by two warning lines
    - ✓ Rope / Wire / Chain Gate or "Other Barricade"
    - ✓ Offset Access

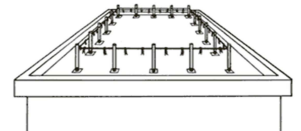



# LADDER REGULATIONS

- Where are temporary ladder regulations found?
  - 1910 – Subpart D
  - 1926 – Subpart X
- Fall protection required?
  - Since both of these are regulations of their own, separate from those for fall protection, OSHA **does not** require a PFAS.
  - That said, the recommendation would be to use one whenever possible.



# FIXED LADDERS

- OSHA requires fall protection on **fixed** ladders at the following heights:
  - 20' – Current Subpart D / 24' Proposed Subpart D
  - 24' – Construction
- Options for protection include:
  - Poor:** Cage / Well
  - Better:** SRL
  - Best:** Vertical Lifeline (VLL)
- VLL Components:
  - Flexible Cable / Rigid Rail
  - Rope / Cable / Bargrab



# MISUSE OF PORTABLE LADDERS

**No standing on the top step!** Employee training on proper use of ladders will help prevent unsafe use.

**Do not use!** Ladders in need of repair must be taken out of service immediately or replaced.

**Danger!** The spreader isn't fully open (WAC 296-876-40050).

Ladder secured to roof.

This one seems properly inclined and secured

# PLAN-PROVIDE-TRAIN

**FALLS FROM ROOFS CAN BE PREVENTED!**

- Wear a harness and always stay connected
- Make sure your harness fits
- Use guardrails or lifelines
- Inspect all fall protection equipment before use
- Guard or cover all holes, openings, and skylights

**PLAN** ahead to get the job done safely.  
**PROVIDE** the right roof equipment.  
**TRAIN** everyone to use the equipment safely.

**DON'T** disconnect from the lifeline

**DON'T** work around unprotected openings or skylights

**DON'T** use defective equipment

U.S. Department of Labor | OSHA | Occupational Safety and Health Administration | 1-800-321-OSHA (6742) | www.osha-slc.gov

# PLAN-PROVIDE-TRAIN

**FALLS FROM LADDERS CAN BE PREVENTED!**

- Choose the right ladder for the job
- Maintain three points of contact
- Secure the ladder
- Always face the ladder

**DON'T** stand on top or on the top step of a step ladder

**DON'T** overreach

**DON'T** place the ladder on uneven footing

**PLAN** ahead to get the job done safely.  
**PROVIDE** the right ladder and equipment.  
**TRAIN** everyone to use the equipment safely.

# PLAN-PROVIDE-TRAIN

**FALLS FROM SCAFFOLDS CAN BE PREVENTED!**

- Use fully planked scaffolds
- Ensure proper access to scaffold
- Plumb and level
- Complete ALL guardrails
- Ensure stable footing
- Inspect before use (by competent person)

**PLAN** ahead to get the job done safely.  
**PROVIDE** the right scaffold and equipment.  
**TRAIN** everyone to use the equipment safely.

**DON'T** stand on guardrails

**DON'T** climb cross-braces

**DON'T** use a ladder on top of a scaffold

## AERIAL LIFT FALL PROTECTION

- Is fall protection required?
- Where is the correct place to attach?
  - What about outside the basket?
  - Basket guardrails?
- Connector Options Hierarchy:
  - 1) Restraint Lanyard
  - 2) PFL
  - 3) Energy-Absorbing Lanyard
- General Prohibitions:
  - Moving large distances w/ the basket elevated
  - Standing on the basket guardrails



## SCAFFOLD SAFETY

- Employees must be trained to safely set up and use scaffolds- this includes safety measures like:
  - During setup: fully plank scaffolds, complete all guardrails, ensure stable footing and plumb and level
  - Ensure proper access to scaffolds
  - A competent person must inspect the scaffold before use
  - Don't climb over cross braces
  - Don't stand on guardrails
  - Don't use a ladder on a scaffold

## SCAFFOLD TYPES

### Supported Scaffold

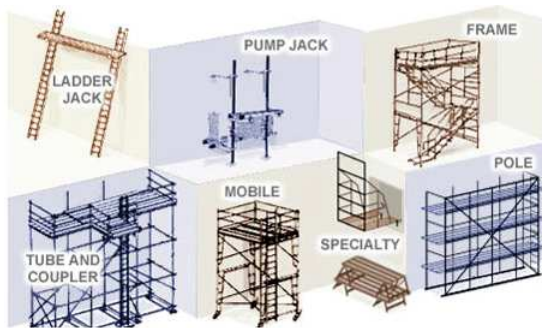

## SCAFFOLD TYPES

### Suspended Scaffold

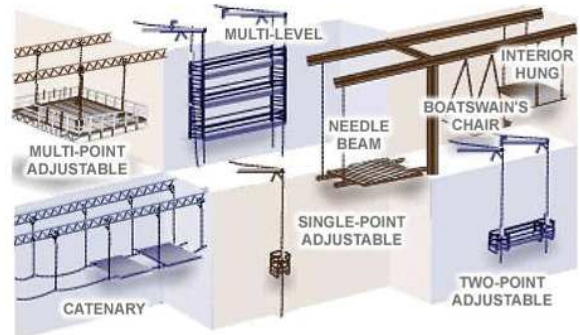

## SCAFFOLDS IN CONSTRUCTION

### Suspended Scaffold



## SCAFFOLDS IN CONSTRUCTION

### Aerial Lift Scaffold



## SCAFFOLDS IN CONSTRUCTION

- Avoiding risks
  - Follow manufacturer's instructions.
  - Install guardrail systems along all open sides and ends of platforms.
  - Personal fall arrest system should be used on scaffolds higher than 10 feet.



## SCAFFOLDS IN CONSTRUCTION

- Falling objects
  - Wear hardhats
  - Barricade area below scaffold
  - Use panels or screens if material is stacked higher than the toe board.



## SCAFFOLD IN CONSTRUCTION

- How many things are wrong here?



## REBAR CAPS

- The OSHA Standard requires that rebar "be guarded to eliminate the hazard of impalement." Not all guards provide that level of protection. In some circumstances, the force of a fall can cause rebar to push clear through a plastic cap and still impale a worker, or the worker can be impaled by the rebar and the cap together.



## REBAR CAPS

- Only rebar caps designed to provide impalement protection, such as those containing steel reinforcement, should be used.
- This type of cap positions a 2 x 4 over the exposed rebar, and has been approved by California OSHA.



## WHAT DOES FALL PREVENTION DO?

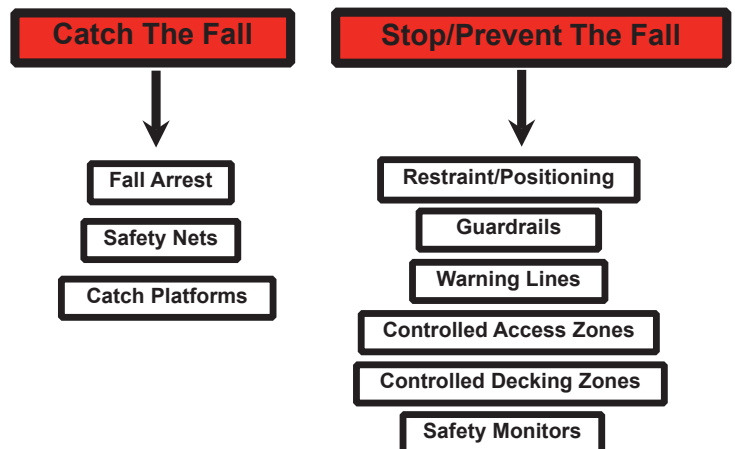



## FALL PROTECTION DEFINITION

- Fall protection is a broad term that used to describe various types of equipment, [systems], and policies that help to minimize the potential for workers to be injured when managing tasks that are high above ground level. Companies often use a combination of safety equipment along with training personnel on how to use it.



FIU

Susan Harwood Training Grant Program

49

## RESULTS OF A FALL

- The average fatal fall is only 6 feet
- A 6' foot fall generates over 3,200 lb of force – that is the approximate weight of an average midsize car
- A fall from 10 feet has an 4 out of 5 probability of causing death or permanent injury
- A fall from 11 feet has an 8.5 out of 10 chance of causing death



FIU

Susan Harwood Training Grant Program

50

## FALL PREVENTION PLANNING

- A fall prevention plan identifies places where regular fall prevention methods, such as guardrails, cannot be used.
- These are called Controlled Access Zones.
- Safety monitoring system should be installed in Controlled Access Zones

FIU

Susan Harwood Training Grant Program

51

## FALL PREVENTION PLANNING

- Fall prevention systems and work practices must be in place before you start work.
- These must be prepared by a qualified person.
- Plan shall be maintained at the job site
- Qualified person should supervise the plan

Falls in Construction/Bridge Decking  
<http://www.youtube.com/watch?v=XSfkJqIE8Dk>

FIU

Susan Harwood Training Grant Program

52

## AUTHORIZED PERSON

- Authorized Person:

A person approved or assigned by the employer to perform a specific type of duty or duties or to be at a specific location or locations at the jobsite.

- This is the “user” of the equipment.
- They know what they need to know in order to be able to perform their particular jobs



FIU

Susan Harwood Training Grant Program

53

## COMPETENT PERSON

- Competent Person:

One who

(1) is capable of identifying

[a] **existing** &

[b] **predictable hazards** in surroundings or work conditions which are unsanitary, hazardous, or dangerous to employees, and

(2) who has **authorization** to take prompt corrective measures to eliminate them.



FIU

Susan Harwood Training Grant Program

54

## QUALIFIED PERSON

### Qualified Person:

One who

- (1) by possession of a
  - [i] *recognized degree*,
  - [ii] *certificate* or
  - [iii] *professional standing*, or



- (2) who by *extensive knowledge, training, and experience*

has successfully demonstrated his ability to **resolve problems** relating to the subject matter, the work, or the project.

## FALL HAZARD ANALYSIS

- Before finding a solution – the hazard must be evaluated.
- Use Hazard or Risk Prediction -- What are the conditions and behaviors to consider?
  - How will we get to the work area?
  - What are the hazards below the work area?
  - How high is the work area?
  - Are there holes or openings below or around the work area?
  - Are there slip or trip hazards around the work area?
  - How difficult is it to rescue someone if they fall?



## FALL PROTECTION REQUIREMENT

- "Unprotected sides and edges." Each employee on a walking/working surface (horizontal and vertical surface) with an unprotected side or edge which is **6 feet (1.8 m) or more** above a lower level shall be protected from falling by the use of guardrail systems, safety net systems, or personal fall arrest systems.
- On scaffolds, fall protection is required at 10 feet.

## AVOIDING FALL HAZARDS

- Construct all floor hole covers so they will effectively support two times the weight of employees, equipment, and materials that may be imposed on the cover at any one time.
- **In general, it is better to use fall prevention systems, such as guardrails, than fall protection systems, such as safety nets or fall arrest devices, because they provide more positive safety means.**

## GUARDRAILS

### 3 Components:

- (1) Top Rail
  - ✓ 42" or 42" +/- 3"
  - ✓ Strength?
- (2) Mid Rail
  - ✓ Midway between top rail and ground (screens / mesh an option)
- (3) Toe Board
  - ✓ Purpose? / Height?
- **Note:**
  - ✓ Rails shall not overhang (due to being a projection hazard).
  - ✓ No steel or plastic banding

## GUARDRAILS



Top Rail  
Mid-Rail  
Toeboard

- Top rails 42 +/- 3 in: between 39 and 45 inches tall
- Toe boards at least 3 1/2 inches high

## IS THIS A GOOD GUARDRAIL?



**FIU**

Susan Harwood Training Grant Program

61

## USE OF SAFETY NETS

- Assumes the fall will occur



**FIU**

Susan Harwood Training Grant Program

62

## SAFETY NET SYSTEMS

- **Safety nets must be inspected** for wear, damage, and other deterioration at least once a week, and after any occurrence which could affect the integrity of the system.
- **Defective nets shall not be used**, and defective components must be removed from service.
- Objects which have fallen into the safety net, such as scrap pieces, equipment, and tools, must be removed as soon as possible from the net and at least before the next work shift.

**FIU**

Susan Harwood Training Grant Program

63

## SAFETY NETS

- Not a debris net
- This is meant to catch falling people.
- Form of collective and passive F.P.
- Sometimes used during work on bridge projects or pre-fab building construction



Safety Net in Residential Construction



SafetyRespect® Safety Net System

**FIU**

Susan Harwood Training Grant Program

64

## SAFETY NETS

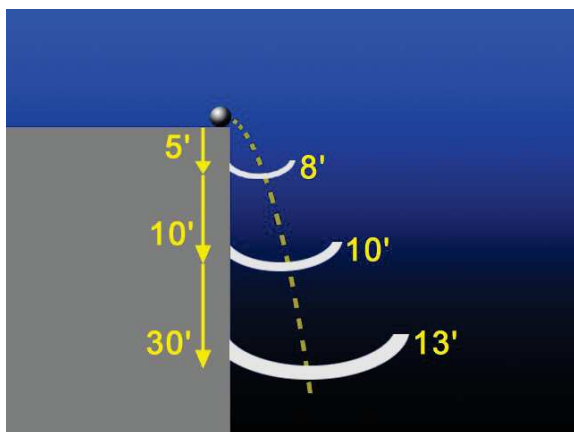

**FIU**

Susan Harwood Training Grant Program

65

## SKYLIGHTS & HOLES

- Skylights & Roof Floor Openings
  - Back / Trip into;
  - Step on weak area of roof;
  - Hole hidden by non-load-supporting covering
- Hole Covers:
  - Be able to support at least twice the load imposed upon them
  - Be secured to prevent accidental displacement



NIOSH FACE Skylight Fatality

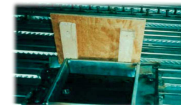

**FIU**

Susan Harwood Training Grant Program

66

## PERSONAL FALL ARREST SYSTEM

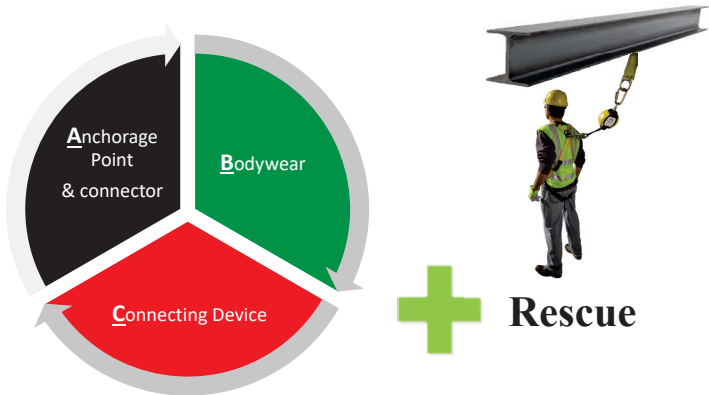

FIU

Susan Harwood Training Grant Program

67

## PERSONAL FALL ARREST SYSTEMS

Includes an anchor point, a lifeline, and a safety harness



FIU

Susan Harwood Training Grant Program

68

## PERSONAL FALL ARREST SYSTEMS

Once a Personal Fall Arrest System has been used in a fall, it must be removed from service right away.

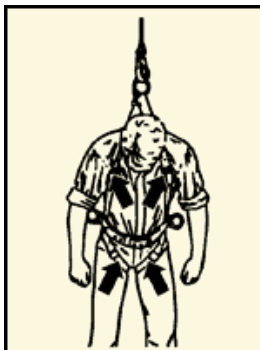

FIU

Susan Harwood Training Grant Program

69

## ANCHORAGE POINT

- Secure location of attachment for the worker's F.P. gear:
- Typical "anchorage / anchor points" include:
  - Large Columns
  - Large Beams
  - Concrete
  - Roof Panel / Understructure
- OSHA Anchorage Requirements:
  - **Option A:** 5,000 lbs.
  - **Option B:** Safety Factor of 2 per a Q.P.



FIU

Susan Harwood Training Grant Program

70

## TEMPORARY ANCHORAGE CONNECTORS



Anchorage Connector Straps / Chain



Workman® FP Stryder™



Workman Reusable Roof Anchor



Removable Concrete Anchorage Connectors

FIU

Susan Harwood Training Grant Program

71

## ANCHORAGE POINT

- Other considerations include:
  - **Location:**
    - ✓ Above
    - ✓ Vertically inline with the worker
  - Note:** Although the picture demonstrates a lanyard, this is a common issue when utilizing self-retracting lifelines (SRLs).
  - **Rescue:**
    - ✓ What does OSHA say about how quickly rescue must take place?
      - ❖ "Prompt"

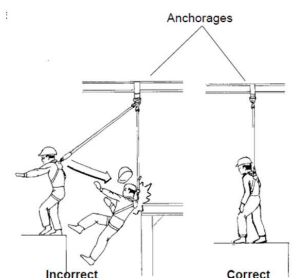

FIU

Susan Harwood Training Grant Program

72



# PERMANENT ANCHORAGE CONNECTORS



D-Plate Anchorage Connector / MEGA Swivel



Fixed Roof Anchor



Weld-On Puck

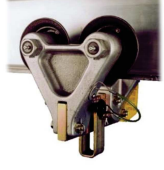

BeamGlide™ Trolley



# CONNECTORS



Connectors



D-Rings



Snaphooks



# CONNECTING DEVICES



Snaphooks

Energy Absorber

Lifeline

## ▪ Snaphooks

- Varying sizes (¾" vs. 2 ½")
- "Compatibility"

✓ ANSI Z359 – 2007 gates



# CONNECTING DEVICES

## Self-Retracting Lifelines

- Drum-wound line is slowly extracted from or retracted back into the housing in normal use
- Like a car seatbelt, locking off in a fall

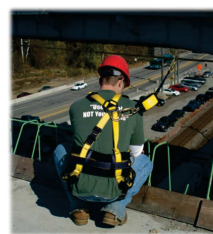
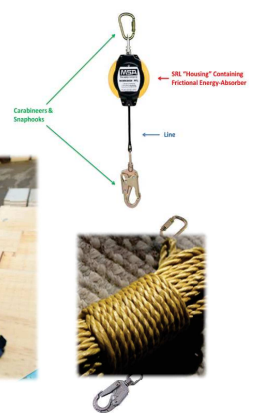

PFL



Web SRL



# PERMANENT HORIZONTAL LIFELINES (HLLS)

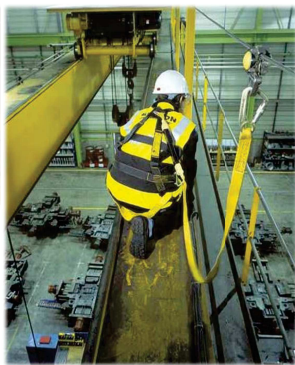

- Designed by a Qualified Person
- No. of workers per system?
  - Limits on # per span
- Systems
  - Specially Engineered



# VERTICAL LIFELINE/LANYARD



# BODY HARNESS



# PFAS INSPECTION



# WEBBING

- Webbing are the ropes and straps used in lifelines, lanyards, and strength components of body harnesses. The webbing must be made from synthetic fibers.



# PERSONAL FALL PROTECTION SYSTEM

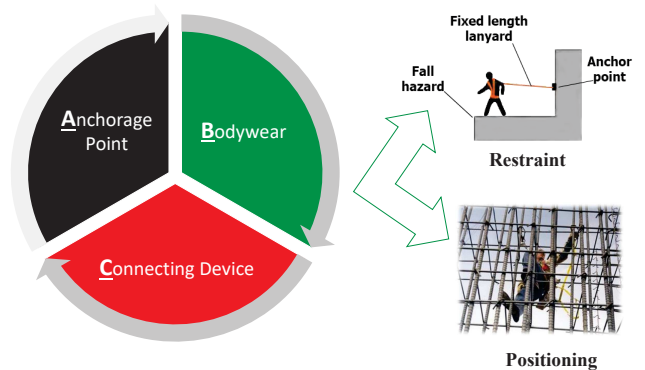

# FALL CLEARANCE - LANYARD

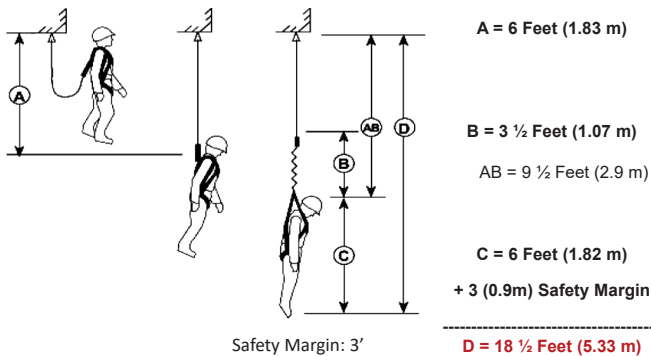

# FALL CLEARANCE - SRL

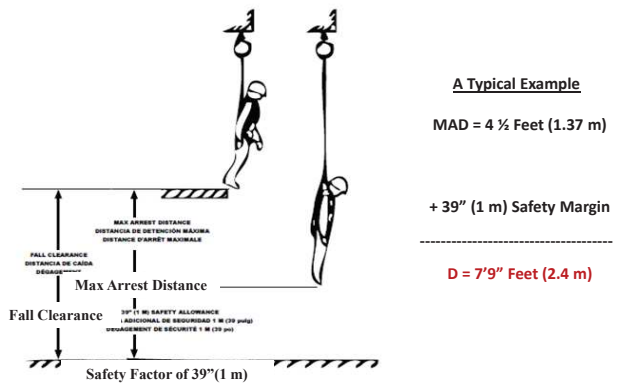

## A FALL WITH A 1.8 M (6 FT) LANYARD

Time	Physical Response	Free-Fall Distance	Velocity
0.1 sec	Unaware	5.1 cm (2 in)	1.0 m/s (3.3 ft/s)
0.2 sec	Aware	20.3 cm (8 in)	2.13 m/s (7 ft/s)
0.5 sec	Start to Move	1.22 m (4 ft)	4.88 m/s (16 ft/s)
0.61 sec	Slight Movement	1.83 m (6 ft)	5.97 m/s (19.6 ft/s)
0.7 sec	Impact	2.41 m (7.9 ft)	7.01 m/s (23 ft/s)
0.9 sec	Rebound	3.96 m (13 ft)	8.84 m/s (29 ft/s)
1.0 sec	Suspend	4.9 m (16 ft)	9.75 m/s (32 ft/s)



**FIU**

Susan Harwood Training Grant Program

85

## ATTACHMENT LOCATION

- The attachment of the body harness must be located in the center of the wearer's back, near the shoulder level, or above the head.



**FIU**

Susan Harwood Training Grant Program

86

## ANSI Z359.14 – 2014

- Class A SRL**
  - “Maximum Arrest Distance” = 24”
  - Average Arrest Force = 1,350 lb. (1,800 lb. peak)
- Class B SRL**
  - “Maximum Arrest Distance” = 54”
  - Average Arrest Force = 900 lb. (1,800 lb. peak)
- “Leading Edge” (LE-SRL)**
  - Inline energy absorber at attachment end to user's back
  - Specifically tested for going over sharp edges
- Factory Recertification**
  - Based on frequency of use from date of service

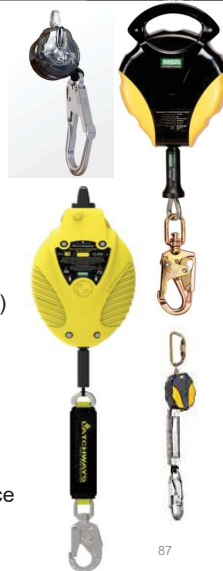

**FIU**

Susan Harwood Training Grant Program

87

## PERSONAL FALL ARREST SYSTEMS

Body belts are not acceptable as part of a personal fall arrest system



**FIU**

Susan Harwood Training Grant Program

88

## FALL PROTECTION - RESCUE PLAN

- Each time fall protection is used, there must be a rescue plan!
  - You must be able to rescue someone in a minimum amount of time.
  - Identify the normal conditions and allowances.
  - Define the plan during the Hazard and Risk Prediction.



**FIU**

Susan Harwood Training Grant Program

89

## RESCUE EQUIPMENT

- Rescue Cradle
  - Person is rescued in a physically neutral position.
- Full Body Harness
  - May be different
  - Allows longer suspension
- Anchthon
  - Self-Rescue
  - Great in a panic
- Rescue Equipment Kits
  - Rescue Utility Set
- Rescue Hoist
  - Confined Space.

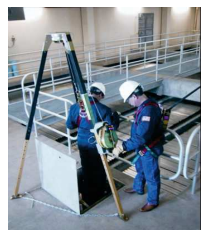

**FIU**

Susan Harwood Training Grant Program

90



# FALL RESCUE PROCEDURES

- Manage the people needed to operate the rescue equipment
- Protect rescue personnel during rescue operations
- Emergency medical technicians should give first aid if needed.
- The fall prevention plan must include provisions for quick rescue.



# FALL PREVENTION OPTIONS

- Platforms and Railing
- Lifts
- Scaffolding
- Ladders
- Fall Restraint System
- Mobile Stairs



# EXAMPLES OF PPE FAILURES



# EXAMPLES OF PPE FAILURES

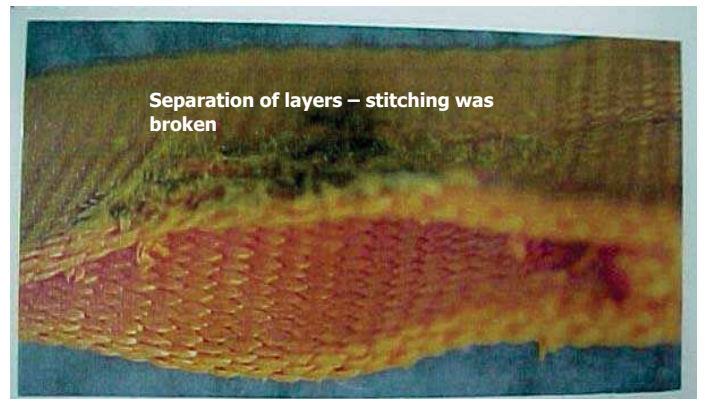

# EXAMPLES OF PPE FAILURES

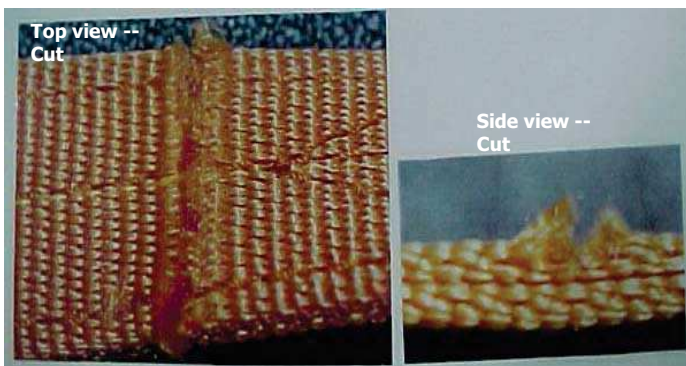

# EXAMPLES OF PPE FAILURES

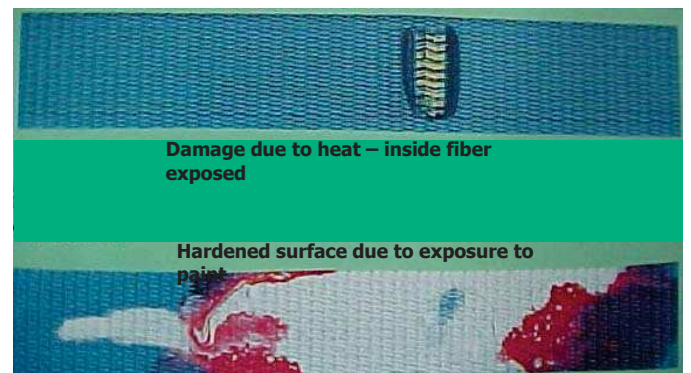



## EXAMPLES OF PPE FAILURES



Outside plastic cover is damaged – inside exposed

Stretching due to force or heat – incorrect shape

**FIU**

Susan Harwood Training Grant Program

97

## EXAMPLES OF PPE FAILURES

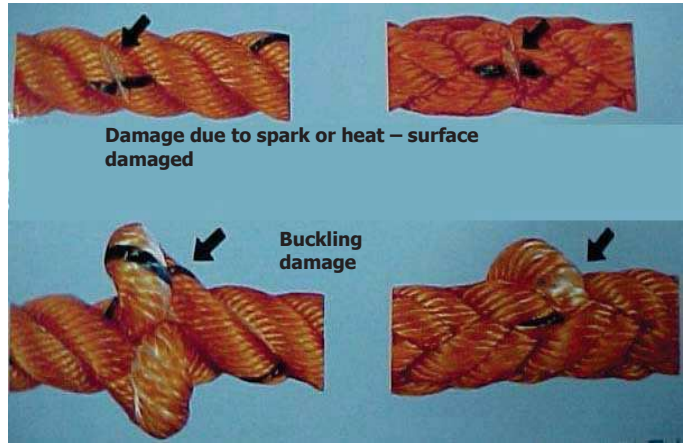

Damage due to spark or heat – surface damaged

Buckling damage

**FIU**

Susan Harwood Training Grant Program

98

## EXAMPLES OF PPE FAILURES



Damage due to chemicals and paint – surface is hardened

**FIU**

Susan Harwood Training Grant Program

99

## WHAT QUESTIONS DO YOU HAVE?

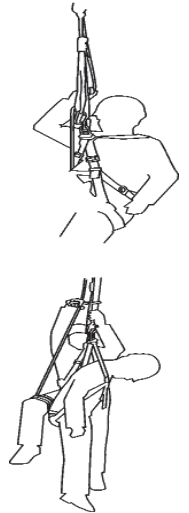

Please

- Answer the pre-test
- Fill the training evaluation form

**FIU**

Susan Harwood Training Grant Program

100

## IS THIS A FALL HAZARD?

**YES**

Workers could fall while climbing on the shoring structure to set it up and remove it.



Ladders and lifts must be provided.

Photos in this presentation are from the OSHA Region 4 National Photo Archive and OSHA Region 5.

**FIU**

Susan Harwood Training Grant Program

101

## IS THIS A FALL HAZARD?

**YES**

Workers must be protected from falls over 6 feet.



Workers are exposed to a fall hazard greater than 6 feet, while working near stairwell opening.

**FIU**

Susan Harwood Training Grant Program

102

# IS THIS A FALL HAZARD?

**YES**

Unprotected open-sided floors 6 feet or more above ground level.



Guardrail systems, safety net systems or personal fall arrest systems are required.

# IS THIS A FALL HAZARD?

**YES**

Workers are installing a new metal roof without fall protection.

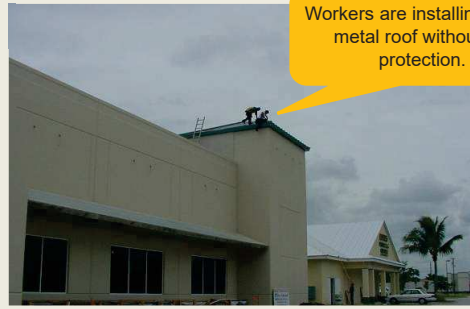

NOTE: Remember that ladders must extend 3 feet above the landing area.

# IS THIS A FALL HAZARD?

**YES**

Lack of fall protection for workers on fabricated frame scaffolds.



Planks appear to be overloaded and there is no safe access for workers.

The workers are exposed to a 35-foot fall hazard from a scaffold while stacking blocks prior to overhand bricklaying operations.

# CAN YOU IDENTIFY THE FALL HAZARD?

**YES**

Ladder to work platform is not of sufficient length.



It must extend 3 feet above the working surface.

# IS THIS A FALL HAZARD?

**YES**

Worker is working off of the top of a step ladder.



The top of a stepladder shall not be used as a step.

# CAN YOU IDENTIFY THE FALL HAZARDS? **YES**

A worker is working from a carpenter's scaffold that has no guardrail, extends too far beyond either end, and is not wide enough.



The worker inside of the window is not provided with fall protection as there is no standard guardrail for the window.

The worker also does not have proper access to the scaffold.

The worker working below is exposed to the struck-by hazards of tools and equipment falling from the employees working above.

NOTE: A competent person must supervise as scaffolds are erected, moved and taken apart.

# IS THIS A FALL HAZARD?



Falls in Construction Re-Roofing  
[http://www.dol.gov/dol/media/webcast/20111031-  
osha/reroofing\\_fnl\\_eng\\_web.htm](http://www.dol.gov/dol/media/webcast/20111031-<br/>osha/reroofing_fnl_eng_web.htm)

**FIU**

Susan Harwood Training Grant Program

109

**YES**

Worker working on an 8:12 pitch roof with only the lifeline tied to his waist as fall protection.

Employer must provide full body harnesses.



**FIU**

Susan Harwood Training Grant Program

110

# IS THIS A FALL HAZARD?



**FIU**

Susan Harwood Training Grant Program

111

**YES**

Scaffolding was not erected with guardrails in areas where workers were working at heights greater than 10 feet.

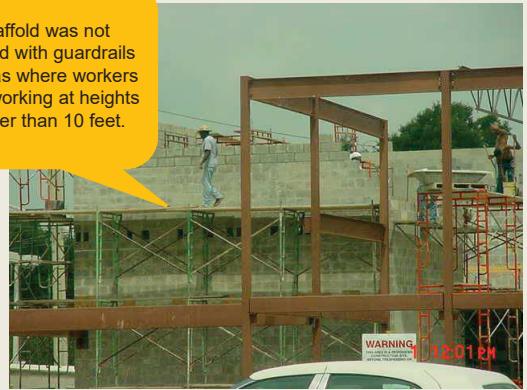

**FIU**

Susan Harwood Training Grant Program

112